

FMCE-0328 EMI Input Filter

28 VOLT INPUT – 3 AMP

FEATURES

- Attenuation to 60 dB at 500 kHz, typical
- Operating temperature -55° to +125°C
- Nominal 28 volt input, -0.5 to 50 volt operation
- Transient rating -0.5 to 80 volts for 1 second
- Up to 3 amps throughput current over the full input voltage range of -0.5 to 50 volts
- Compliant to
 - MIL-STD-461C CE03
 - MIL-STD-461D, E and F CE102
 - MIL-STD-461C CS01
 - MIL-STD-461D, E and F CS101
- Compatible with MIL-STD-704 A-E 28 volt power bus

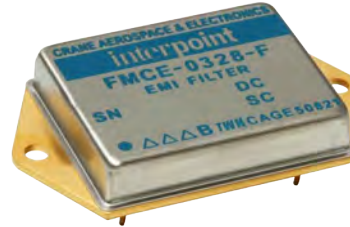

FMCE-0328	
INPUT (V)	CURRENT (A)
0 - 50	3

DESCRIPTION

The Interpoint® FMCE-0328 Series™ of EMI filters offers up to 3 amps of throughput current in a low profile package. The FMCE-0328 filters are manufactured in our fully certified and qualified MIL-PRF-38534 Class H production facility and packaged in hermetically sealed steel cases. They are ideal for use in programs requiring high reliability and small size. The FMCE-0328 filter is specifically designed to reduce the input line reflected ripple current of Interpoint high frequency DC-DC converters such as MFX, MTR, MWR, MHF+ and MHV Series. These filters are intended for use in 28 volt applications. At 50 volts input (high line), the filter provides 150 watts of throughput power.

The FMCE-0328 filters are built using thick-film hybrid technology and are hermetically sealed in metal packages for military, aerospace, and other high-reliability applications. Only ceramic capacitors are used in the filters to ensure reliable high temperature operation.

The filters are offered with standard screening, “ES” screening, or fully compliant to “883” MIL-PRF-38534 Class H screening. See Table 6 on page 8 and Table 7 on page 9. DLA Land and Maritime Drawings are available. See Table 2 on page 3.

MIL-STD NOISE MANAGEMENT

When used in conjunction with Interpoint converters, the FMCE-0328 filters reduce input ripple current within the frequency band of 100 kHz to 50 MHz. When used with an Interpoint converter, performance exceeds the CE03 test of MIL-STD-461C and meets the requirements of CS01 of MIL-STD-461C. These filters also meet CE102 and CS101 of MIL-STD-461D, E and F.

OPERATING TEMPERATURE

The filters are rated to operate, with no degradation of performance, over the temperature range of -55°C to +125°C (as measured at the baseplate). Current is derated linearly to 80% at +135°C case temperature. See Table 4 and Table 5 on page 4.

INSERTION LOSS

Low DC resistance design results in a maximum power loss of less than 2% with typical input voltage.

FMCE-0328 EMI Input Filter

28 VOLT INPUT – 3 AMP

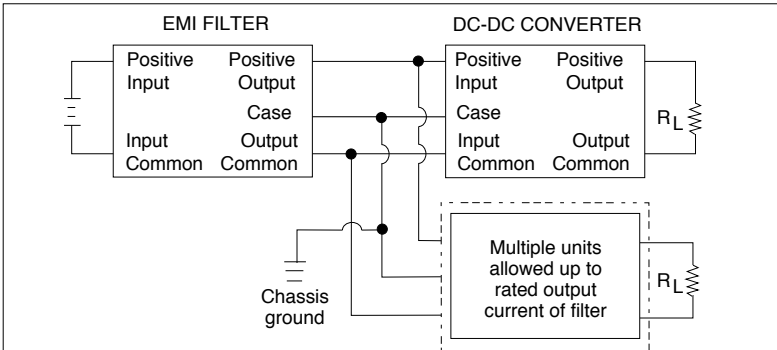

The case ground connection between the filter and the converter should be as low an impedance as possible to minimize EMI. Direct contact of baseplate to chassis ground provides the lowest impedance.

FIGURE 1: CONNECTION DIAGRAM

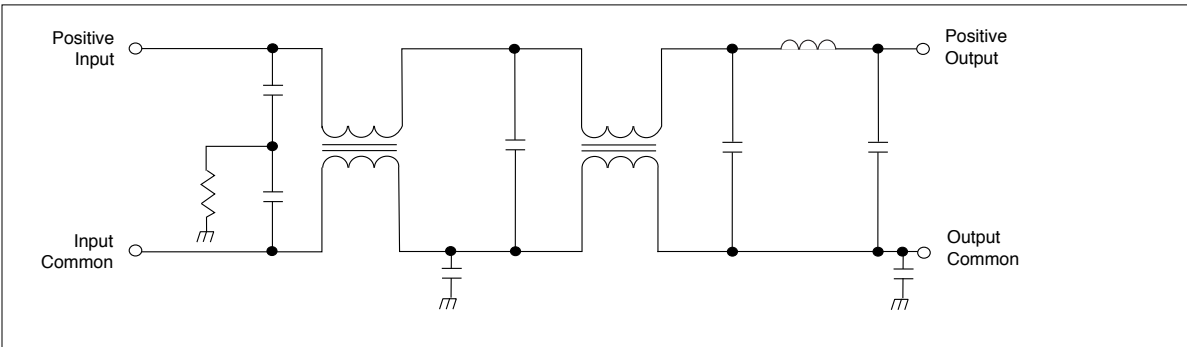
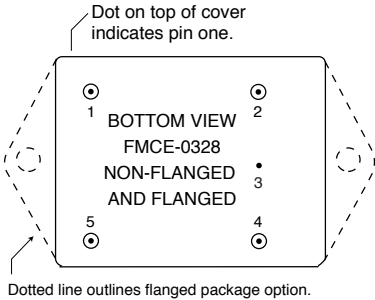

FIGURE 2: SCHEMATIC - FMCE-0328

PIN OUT	
Pin ¹	Designation
1	Positive Input
2	Positive Output
3	Case Ground
4	Output Common
5	Input Common

Notes
1. All pins must be connected.

TABLE 1: PIN OUT



See Figure 10 on page 6 and Figure 11 on page 7 for dimensions.

FIGURE 3: PIN OUT

FMCE-0328 EMI Input Filter

28 VOLT INPUT – 3 AMP

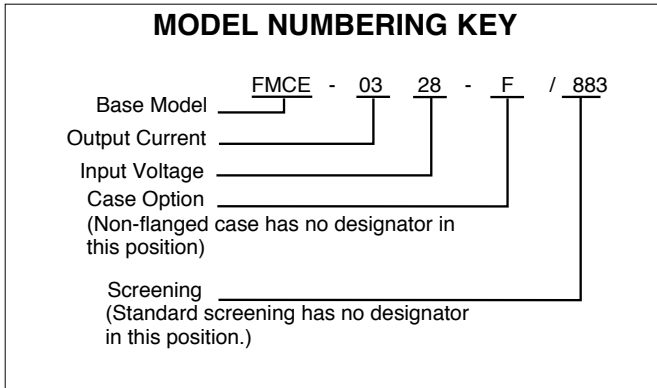

DLA NUMBERS	
DLA DRAWING (5915)	FMCE-0328 SIMILAR PART
10015-01HXC	FMCE-0328/883
10015-01HZC	FMCE-0328-F/883
For exact specifications for a DLA product, refer to the DLA drawing. DLA drawings can be downloaded from: https://landandmaritimeapps.dla.mil/programs/smcr/	

TABLE 2: DLA CROSS REFERENCE

FIGURE 4: MODEL NUMBERING KEY

MODEL NUMBER OPTIONS ¹				
TO DETERMINE THE MODEL NUMBER ENTER ONE OPTION FROM EACH CATEGORY IN THE FORM BELOW.				
CATEGORY	Base Model and Input Voltage	Case Option ²		Screening ³
OPTIONS	FMCE-0328	(Standard, leave blank) F (flanged)		(standard, leave blank) ES 883
FILL IN FOR MODEL # ⁴	FMCE-0328	_____	/	_____
Notes 1. See Figure 4 above for an example of a model number. 2. Case Options: For the standard case, Figure 10 on page 6, leave the case option blank. For the flanged case option, Figure 11 on page 7, insert the letter F in the Case Option position. 3. Screening: See Table 6 on page 8 and Table 7 on page 9 for more information. Use "ES" for "ES" screening and "883" for Class H (MIL-PRF-38534) screening. 4. If ordering by model number add a "-Q" to request solder dipped leads (FMCE-0328/883-Q). Available only for "883" (Class H).				

TABLE 3: MODEL NUMBER OPTIONS

FMCE-0328 EMI Input Filter

28 VOLT INPUT – 3 AMP

TABLE 4: OPERATING CONDITIONS

MODEL		FMCE-0328			UNITS
PARAMETER	CONDITIONS	MIN	TYP	MAX	
LEAD SOLDERING TEMPERATURE ¹	10 seconds max.	–	–	300	°C
STORAGE TEMPERATURE ¹		-65	–	+150	°C
CASE OPERATING TEMPERATURE ¹	FULL POWER	-55	–	+125	°C
	ABSOLUTE	-55	–	+135	
DERATING OUTPUT POWER/CURRENT ¹	LINEARLY	From 100% at 125°C to 80% at 135°C			
ESD RATING ^{1, 2}	MIL-STD-883, METHOD 3015	≥8000			V
MIL-PRF-38534, 3.9.5.8.2	CLASS 3B				
ISOLATION, ANY PIN TO CASE EXCEPT CASE PIN	500 VDC AT 25°C	100	–	–	Megohms

Notes

1. Guaranteed by characterization test and/or analysis. Not a production test.
2. Passes 8000 volts.

TABLE 5: ELECTRICAL CHARACTERISTICS: -55°C to +125°C T_C, UNLESS OTHERWISE SPECIFIED.

MODEL		FMCE-0328			UNITS
PARAMETER	CONDITIONS	MIN	TYP	MAX	
INPUT VOLTAGE ¹	CONTINUOUS	-0.5	28	50	V
	TRANSIENT 1 second ²	–	–	80	V
NOISE REJECTION	500 kHz	50	60	–	dB
	1 MHz	55	60	–	
DC RESISTANCE (R _{DC})	T _C = 25°C	–	0.170	0.200	Ω
	T _C = -55° to +125°C ¹	–	0.200	0.250	
CAPACITANCE T _C = 25°C	ANY PIN TO CASE EXCEPT CASE PIN	–	22,000	24,000	pF
OUTPUT VOLTAGE ^{1, 3}	STEADY STATE	$V_{OUT} = V_{IN} - I_{IN} (R_{DC})$			V
OUTPUT CURRENT ¹	STEADY STATE	–	–	3	A
POWER DISSIPATION ¹	T _C = 25°C	–	1.5	1.5	W
	T _C = -55° to +125°C	–	–	2.25	

Notes

1. Guaranteed by characterization test and/or analysis. Not a production test.
2. 0.5 ohm source impedance.
3. Typical applications result in V_{out} within 2% of V_{IN}.

FMCE-0328 EMI Input Filter

28 VOLT INPUT – 3 AMP

TYPICAL PERFORMANCE PLOTS: 25°C CASE, UNLESS OTHERWISE SPECIFIED.
FOR REFERENCE ONLY, NOT GUARANTEED SPECIFICATIONS.

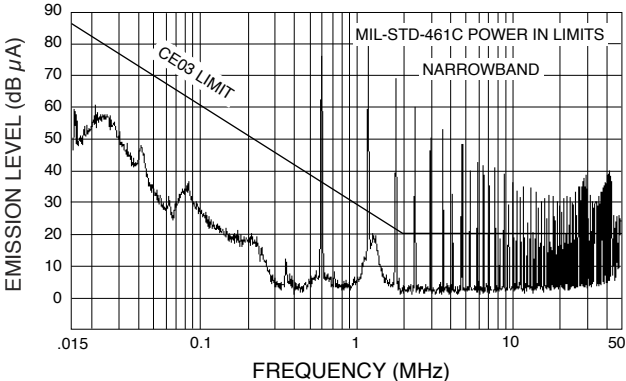

High power DC-DC converter without filtering.

FIGURE 5

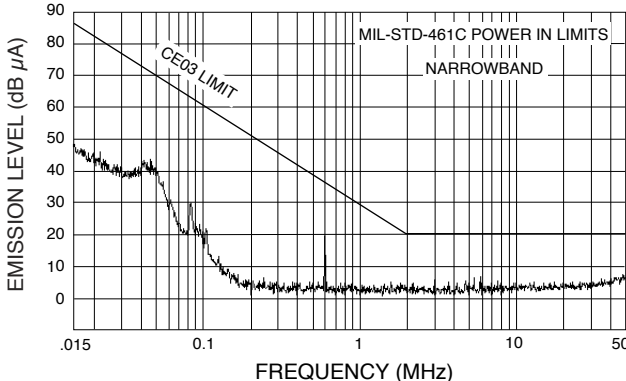

CE03: High power DC-DC converter filtered with an FMCE-0328

FIGURE 6

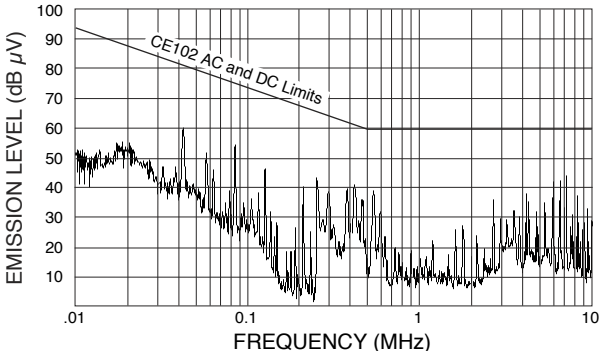

CE102: High power DC-DC converter filtered with an FMCE-0328.

FIGURE 7

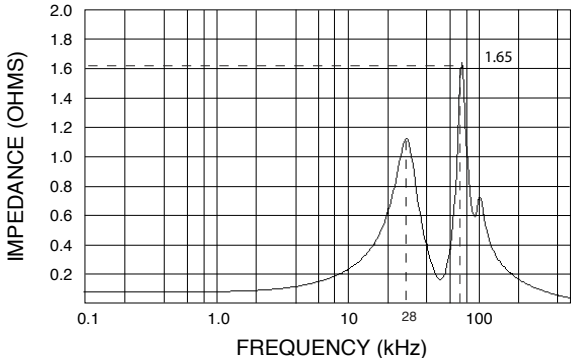

FMCE-0328 Output Impedance (measured at the output with input pins shorted)

FIGURE 8

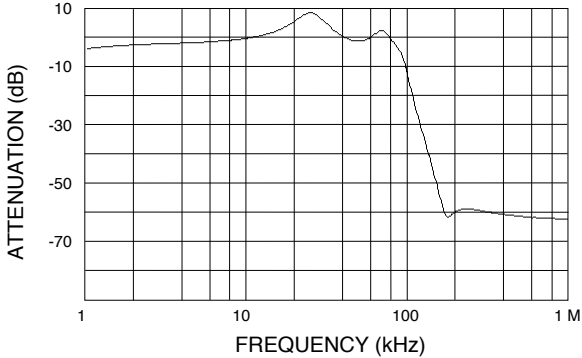

FMCE-0328 Attenuation

FIGURE 9

FMCE-0328 EMI Input Filter

28 VOLT INPUT – 3 AMP

BOTTOM VIEW CASE E3

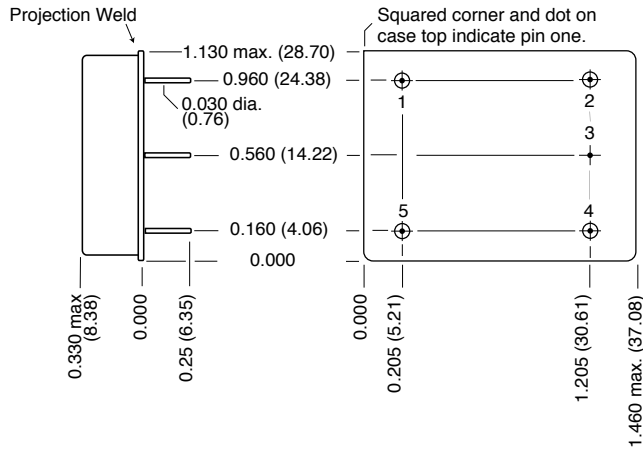

Weight: 32 grams maximum

Case dimensions in inches (mm)

Tolerance ± 0.005 (0.13) for three decimal places
 ± 0.01 (0.3) for two decimal places
 unless otherwise specified

CAUTION

Heat from reflow or wave soldering may damage the device. Solder pins individually with heat application not exceeding 300°C for 10 seconds per pin.

Materials

Header Cold Rolled Steel/Nickel/Gold
 Cover Kovar/Nickel
 Pins #52 alloy/Gold compression glass seal.
 Seal Hole: 0.080 ± 0.002 (2.03 ± 0.05)

Please refer to the numerical dimensions for accuracy.

FIGURE 10: CASE E3

FMCE-0328 EMI Input Filter

28 VOLT INPUT – 3 AMP

BOTTOM VIEW CASE G3

Flanged cases: Designator "F" required in Case Option position of model number

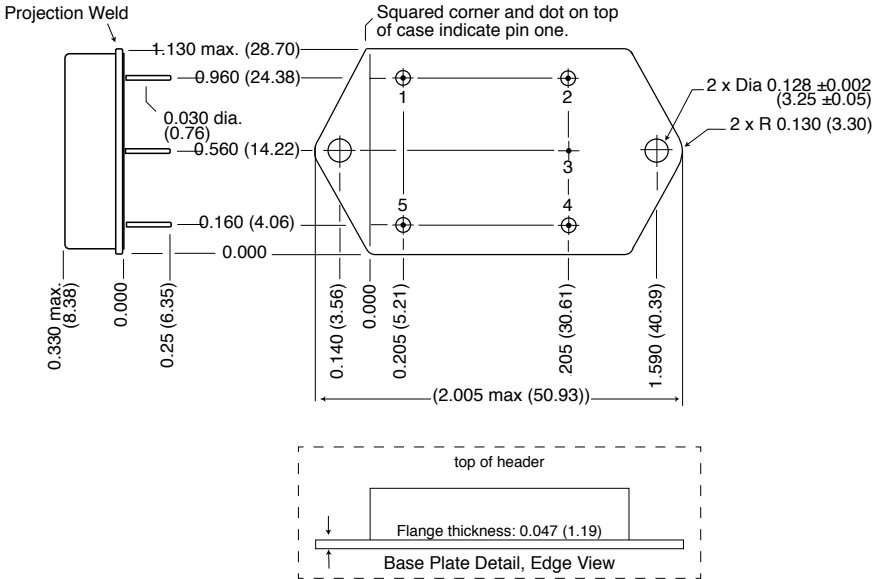

Weight: 32 grams maximum

Case dimensions in inches (mm)
Tolerance ± 0.005 (0.13) for three decimal places
 ± 0.01 (0.3) for two decimal places
unless otherwise specified

CAUTION
Heat from reflow or wave soldering may damage the device. Solder pins individually with heat application not exceeding 300°C for 10 seconds per pin.

Materials
Header Cold Rolled Steel/Nickel/Gold
Cover Kovar/Nickel
Pins #52 alloy/Gold compression glass seal.
Seal Hole: 0.080 ± 0.002 (2.03 ± 0.05)

Please refer to the numerical dimensions for accuracy.

FIGURE 11: CASE G3

FMCE-0328 EMI Input Filter

28 VOLT INPUT – 3 AMP

ELEMENT EVALUATION ¹ HIGH RELIABILITY /883 (CLASS H)

COMPONENT-LEVEL TEST PERFORMED	QML	
	CLASS H /883	
	M/S ²	P ³
Element Electrical	■	■
Visual	■	■
Internal Visual	■	
Final Electrical	■	■
Wire Bond Evaluation	■	■

- Notes
1. Element evaluation does not apply to standard and /ES product.
 2. M/S = Active components (microcircuit and semiconductor die).
 3. P = Passive components, Class H element evaluation. Not applicable to standard and /ES element evaluation.

TABLE 6: ELEMENT EVALUATION

FMCE-0328 EMI Input Filter

28 VOLT INPUT – 3 AMP

ENVIRONMENTAL SCREENING HIGH RELIABILITY STANDARD, /ES AND /883 (CLASS H)

TEST PERFORMED	NON-QML ¹		CLASS H QML ²
	STANDARD	/ES	/883 QML
Pre-cap Inspection, Method 2017, 2032	■	■	■
Temperature Cycle (10 times)			
Method 1010, Cond. C, -65°C to +150°C, ambient			■
Method 1010, Cond. B, -55°C to +125°C, ambient		■	
Constant Acceleration			
Method 2001, 3000 g			■
Method 2001, 500 g		■	
PIND, Test Method 2020, Cond. A			■ ³
Burn-in Method 1015, +125°C case, typical ⁴			
96 hours		■	
160 hours			■
Final Electrical Test, MIL-PRF-38534, Group A,			
Subgroups 1 through 6, -55°C, +25°C, +125°C case			■
Subgroups 1 and 4, +25°C case	■	■	
Hermeticity Test			
Gross Leak, Cond. C ₁ , fluorocarbon		■	■
Fine Leak, Cond. A ₂ , helium		■	■
Gross Leak, Dip	■		
Final visual inspection, Method 2009	■	■	■

Test methods are referenced to MIL-STD-883 as determined by MIL-PRF-38534.

Notes

1. Non-QML products may not meet all of the requirements of MIL-PRF-38534.
2. All processes are QML qualified and performed by certified operators.
3. Not required by DLA but performed to assure product quality.
4. Burn-in temperature designed to bring the case temperature to +125°C minimum.
Burn-in is a powered test.

TABLE 7: ENVIRONMENTAL SCREENING