

Maximum Flexible Power (MFP) Single Output Point of Load

MFP0507S, 3 TO 6 VOLT INPUT, 7 AMP, DC-DC CONVERTER

**MAXIMUM FLEXIBLE POWER (MFP) IN A SINGLE 7 AMP POINT OF LOAD.
A USE-ANYWHERE POWER SOLUTION FOR DIGITAL AND NON-DIGITAL SYSTEMS.**

FEATURES

- Radiation tolerant space DC-DC converter
 - Single event effects (SEE) LET performance to 85 MeV cm²/mg
 - Total ionizing dose (TID) guaranteed per MIL-STD-883 method 1019, radiation hardness assurance (RHA) P = 30 krad(Si), L = 50 krad(Si), R = 100 krad(Si)
 - 50 - 300 rad(Si)/sec dose rate (Condition A)
 - LDR tested to 30 krad at 10 mrad(Si)/sec dose rate (Condition D)
- No external components required
- Up to 92% typical efficiency, flat down to 30% load
- Qualified up to MIL-PRF-38534 Class K
- Input voltage range 3.0 to 6.0 volts dc
- Input transient survivability to 15 volts for up to 1 sec.
- Inhibit and sync functions
- Current monitoring
- Current sharing pin for parallel operation
- Four pin-selectable, preset voltages
 - 0.8, 1.6, 2.5 and 3.3
- Output voltage continuously adjustable
 - from 0.8 to 3.5 volts with resistors
- Indefinite output short circuit protection
- Adjustable start-up sequencing
- Remote sense and voltage margining
- Internal solid state power switch provides many benefits including inrush current limiting

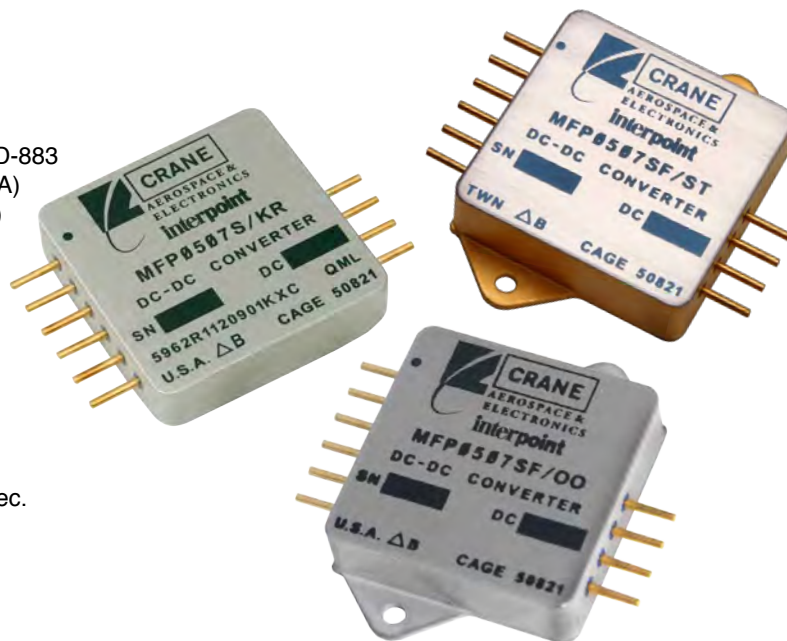

DESCRIPTION

The MFP Series™ DC-DC converters do not require any external components to achieve all specified performance levels. They are a high-reliability, high-efficiency point of load converter for use with a 3.3 volt input bus or a 5.0 volt input bus with an undervoltage shutdown below 3.0 volts and an overvoltage shutdown above 6.0 volts. The MFP0507S model has the flexibility to be set for any output voltage from 0.64 to 3.5 volts. The converter can withstand up to a 15 volts transient for up to 1 second.

The non-isolated, feature-rich MFP uses a Buck converter design with synchronous rectification. The design allows the unit to operate synchronously to no output load, ensuring high efficiency at the lightest loads without switching off the synchronous devices. Important features include a solid state switch, inrush current limiting, synchronization with an external system clock and the ability to current share allowing multiple devices to supply a common load.

The MFP includes an internal house keeping supply that is active at inputs as low as 2 volts and provides a boosted and regulated voltage supply for internal use. This internal supply is one of the reasons that this product can provide full power at very high efficiency at input voltages as low as 3 volts. No external power source or external bias is required.

The MFP converters are designed for the large, fast transient load currents typical to digital loads. See Figure 5 on page 12. The MFP Series is intended to be powered by a fully regulated power source.

HISTORY OF PROVEN PERFORMANCE

Crane Aerospace & Electronics, Power Solutions was issued its first standard microcircuit drawing (SMD) in 1992 for an Interpoint® Class H hybrid. Our first Class K hybrid SMD was issued in 1997 and we were one of the first companies to certify manufacturing to Class K. Our Redmond site has a Defense Logistics Agency (DLA) approved Radiation Hardness Assurance (RHA) plan. Our products are on DLA SMDs with RHA P, L or R for 30, 50 and 100 krad(Si), respectively.

Maximum Flexible Power (MFP) Single Output Point of Load

MFP0507S, 3 TO 6 VOLT INPUT, 7 AMP, DC-DC CONVERTER

TABLE OF CONTENTS

Electrical Characteristics Tables	Pin Functions and Applications
Table 1: Absolute Maximum Ratings 3	Figure 5: Typical Connection Diagram 12
Table 2: Input Specifications 3	ENABLE 13
Table 3: Output Specifications 4	SYNC 13
	Figure 6: ENABLE and SYNC Equivalent Circuit 13
Pin Out	Table 8: Enable Capacitance Values 13
Table 4: MFP0507S Pin Out 6	+V _{IN} and V _{IN} Common 14
	Figure 7: Input voltage vs Maximum Output Voltage 14
Model Numbering Information and SMD Number	SENSE 15
Figure 1: Model Numbering Key 7	Figure 8: SENSE Pin Voltage Margining 15
Table 5: SMD Number Cross Reference 7	SHARE 16
Table 6: Model Number Options 7	Figure 9: Typical Share Connection 16
Mechanical Information	TRIM A and TRIM B 17
Figure 2: MFP0507S Case Dimensions 8	Table 9: User Configurable Output Voltages 17
Figure 3: MFP0507SF Case Dimensions 9	+V _{OUT} and V _{OUT} Common 17
	Figure 10: Maximum Rated Output Current 17
Thermal and Mounting Considerations	Typical Performance Plots
Thermal Considerations 10	Figure 11: Typical Efficiencies 18
Figure 4: Infrared Image MFP at Full Load 10	Figure 12: Input Ripple, 3 V _{IN} 18
Mounting Considerations 11	Figure 13: Input Ripple, 5 V _{IN} 18
Table 7: Chomeric Material Specifications 11	Figure 14: Output Ripple, 1.2 V _{OUT} 18
	Figure 15: Output Ripple, 3.3 V _{OUT} 18
	Figure 16: Load Transient Response, 1.2 V _{OUT} 18
	Figure 17: Load Transient Response, 3.3 V _{OUT} 18
	Figure 18: SHARE as Monitor for Output Current 19
	Figure 19: Operating Frequency vs Temperature and V _{IN} 19
	Screening Tables
	Table 10: Element Evaluation. 20
	Table 11: Environmental Screening and RHA Levels. 21

Maximum Flexible Power (MFP) Single Output Point of Load

MFP0507S, 3 TO 6 VOLT INPUT, 7 AMP, DC-DC CONVERTER

ELECTRICAL CHARACTERISTICS:

-55 to +125°C T_C , 5 V_{IN} , 3.3 V_{OUT} , nominal frequency, unless otherwise specified.

TABLE 1: ABSOLUTE MAXIMUM RATINGS

PARAMETER	CONDITION	FIGURE	SYMBOL	MIN	TYP	MAX	UNITS
OPERATING TEMPERATURE 883, HP, HL, HR, KP, KL AND KR	All	—	T_C	-55	—	+125	°C
STORAGE TEMPERATURE	All	—	T_{STG}	-65	—	+150	°C
DERATING OUTPUT POWER/CURRENT	Linearly	From 100% at 125°C to 0% at 135°C					
MAXIMUM WEIGHT – MFP0507S	—	Figure 2	—	—	—	26	grams
ESD RATING ¹ MIL-PRF-38534, 3.9.5.8.2, MIL-STD-883	METHOD 3015	—	—	Class 1B 500 - 999 ²			V
LEAD SOLDERING TEMPERATURE ¹	10 seconds max	—	—	—	—	300	°C

Table 1 Notes

- Caution: Heat from reflow or wave soldering may damage the device. Solder pins individually with heat application not exceeding 300°C for 10 seconds per pin.
- Passed 500 volts.

TABLE 2: INPUT SPECIFICATIONS

PARAMETER	STATE	CONDITION	FIGURE	SYMBOL	MIN	TYP	MAX	UNITS	
Input Voltage Range See Note 1	Continuous		Figure 7	V_{IN}	0	5.0	6.0	V	
		Operating	$V_{OUT} = V_1, V_2$	Figure 7	V_{IN}	3.0	3.3 or 5.0	6.0	V
			$V_{OUT} = V_1, V_2, V_3$	Figure 7		3.3	3.3 or 5.0	6.0	
	See Note 2	$V_{OUT} = V_1, V_2, V_3, V_4$	Figure 7		4.5	5.0	6.0		
	Transient ³		Figure 7	$V_{IN\ TRAN}$	—	—	15	V	
Input Current	No Load	$V_{IN} 3.3\ V, V_{OUT} 0.8\ V$	—	I_{IN}	—	210	300	mA	
		$V_{IN} 5.0\ V, V_{OUT} 3.3\ V$	—		—	135	180		
	Disabled ⁴	$V_{IN} 3.3\ V$	—		—	105	145		
		$V_{IN} 5.0\ V$	—		—	50	90		
Enable/Disable Input	Open Circuit Voltage	Pin 1 Open $V_{IN} 3.0\ to\ 6.0\ V$	Figure 6	$V_{PIN\ 1}$	1.6	2.0	2.6	V	
	Threshold Unit Enabled	$V_{IN} 3.0\ to\ 6.0\ V$	Figure 6	$V_{PIN\ 1}$	2.3	—	—		
	Threshold Unit Disabled				—	—	1.4		
	ENABLE Pin Current Unit Disabled				$I_{PIN\ 1}$	—	—	2	mA
External Synchronization	Standard Sync Range	$I_{OUT} 5\ A$	Figure 6	—	270	—	600	kHz	
	Amplitude		—	—	3.0	5.0	6.0	V	
	Duty Cycle ⁵		—	—	40	50	60	%	
	Frequency Source Impedance		—	—	—	—	—	50	Ohms

Maximum Flexible Power (MFP) Single Output Point of Load

MFP0507S, 3 TO 6 VOLT INPUT, 7 AMP, DC-DC CONVERTER

ELECTRICAL CHARACTERISTICS:

-55 to +125°C T_C; 5 V_{IN}; 3.3 V_{OUT}; nominal frequency, unless otherwise specified.

TABLE 2: INPUT SPECIFICATIONS (CONTINUED)

PARAMETER	STATE	CONDITION	FIGURE	SYMBOL	MIN	TYP	MAX	UNITS
Switching Frequency	-55 to +125°C	I _{OUT} 5 A	Figure 19	—	270	—	400	kHz
Power Dissipation	No Load		—	—	—	—	0.9	W
	Fault Power, Output Short ⁶		—	—	—	2.8	4.25	
Input Ripple Current 20 Hz – 20 MHz	V ₁ (0.8 V)	V _{IN} 3.3, I _{OUT} 5 A	—		—	200	290	mA p-p
	V ₄ (3.3 V)	V _{IN} 5.0, I _{OUT} 5 A	—		—	200	310	
	I _{RMS}	—	—		—	—	60	—

Table 2 – Notes

- When powering from 0 volts to the minimum specified input voltage, it is recommended to use a voltage ramp time of 1 millisecond or less. The maximum voltage ramp time does not apply when releasing the ENABLE pin while power is applied.
- 50 microsecond minimum transition time. Transient duration less than 1 second.
- V_{OUT}: V₁ = 0.8 V, V₂ = 1.6 V, V₃ = 2.5 V, V₄ = 3.3 V
- The input current during disable is measured with an external 90 uF capacitor connected across VIN and VIN COM. This capacitor is not required during normal or disabled operations.
- T_{RISE}/T_{FALL} must be less than 50 ns.
- At greater than 50 krad(Si) TID exposure, the converter output may not recover from an externally induced short circuit on its output and may require cycling of input power or inhibit reset to resume normal operation once the load fault condition is removed.

TABLE 3: OUTPUT SPECIFICATIONS

PARAMETER	STATE	CONDITION	FIGURE	SYMBOL	MIN	TYP	MAX	UNITS
Operating Voltage Accuracy ¹	V ₁ 0.8, 25°C	2.5 A Load	Figure 5	V ₁	0.789	0.800	0.815	V
	V ₁ 0.8, -55 to +125°C				0.772		0.826	
	V ₂ 1.6, 25°C		Figure 5	V ₂	1.578	1.600	1.632	V
	V ₂ 1.6, -55 to +125°C				1.538		1.644	
	V ₃ 2.5, 25°C		Figure 5	V ₃	2.447	2.500	2.531	V
	V ₃ 2.5, -55 to +125°C				2.381		2.546	
	V ₄ 3.3, 25°C		Figure 5	V ₄	3.236	3.300	3.347	V
V ₄ 3.3, -55 to +125°C	3.184	3.364						
Load Regulation ¹ V _{OUT} V ₁ , V ₂ , V ₃ , V ₄	25°C	50% Load to Full	—	V _{R LOAD}	—	—	20	mV
	-55 to +125°C	Rated Load			—		20	
Line Regulation ¹ V _{OUT} V ₁ , V ₄	25°C	V ₁ V _{IN} 3-6 V, I _{OUT} 7 A	—	V _{R LINE}	—	—	20	mV
	-55 to +125°C	V ₄ V _{IN} 4.5-6 V, I _{OUT} 5 A			—		20	
Output Ripple and Noise 20 Hz to 20 MHz	-55 to +125°C	V _{IN} 3.3 V, V _{OUT} 0.8 V, I _{OUT} 5 A	Figure 14	V _{OUT-RIP}	—	25	70	mV p-p
	-55 to +125°C	V _{IN} 5.0 V, V _{OUT} 3.3 V, I _{OUT} 5 A	Figure 15		—	40	80	
Output Current ¹	V ₁ 0.8, -55 to +125°C	V _{IN} 3.0 to 6.0 V	Figure 9	I _{OUT}	0	—	7.0	A
	V ₂ 1.6, -55 to +125°C				0	—	6.4	
	V ₃ 2.5, -55 to +125°C				0	—	5.0	
	V ₄ 3.3, -55 to +125°C				0	—	5.0	

Maximum Flexible Power (MFP) Single Output Point of Load

MFP0507S, 3 TO 6 VOLT INPUT, 7 AMP, DC-DC CONVERTER

ELECTRICAL CHARACTERISTICS:

-55 to +125°C T_C, 5 V_{IN}, 3.3 V_{OUT}, nominal frequency, unless otherwise specified.

TABLE 3: OUTPUT SPECIFICATIONS (CONTINUED)

PARAMETER	STATE	CONDITION	FIGURE	SYMBOL	MIN	TYP	MAX	UNITS
Output Power ¹	V ₁ 0.8, -55 to +125°C	V _{IN} 3.0 to 6.0 V	Figure 9	P _{OUT}	0	—	5.6	W
	V ₂ 1.6, -55 to +125°C				0	—	10.2	
	V ₃ 2.5, -55 to +125°C	V _{IN} 3.0 to 6.0 V			0	—	12.5	
	V ₄ 3.3, -55 to +125°C	V _{IN} 4.5 to 6.0 V			0	—	16.5	
External Load Capacitance ²	—	—	—	—	—	—	5000	μF
Efficiency ¹	V ₁ 0.8, 25°C	I _{OUT} 5 A	Figure 11	EFF ₁	70.0	73	—	%
	V ₁ 0.8, -55 to +125°C				67.4	—	—	
	V ₂ 1.6, 25°C		Figure 11	EFF ₂	81.8	84	—	%
	V ₂ 1.6, -55 to +125°C				80.0	—	—	
	V ₃ 2.5, 25°C		Figure 11	EFF ₃	87.3	89	—	%
	V ₃ 2.5, -55 to +125°C				85.8	—	—	
	V ₄ 3.3, 25°C		Figure 11	EFF ₄	90.1	92	—	%
V ₄ 3.3, -55 to +125°C	88.8	—			—			
Turn On Peak Deviation, V _{OUT} , V ₄ ^{1, 3}	Release of Enable	I _{OUT} No Load to Full	—	—	—	—	50	mV pk
	V _{IN} Step Start	V _{IN} 0 to 5.0 V	—	—	—	—	50	
Turn On Settling Time to 2%, V _{OUT} , V ₄ ^{1, 3}	Release of Enable	I _{OUT} No Load to Full	—	—	—	3.2	5	ms
	V _{IN} Step Start	V _{IN} 0 to 5.0 V	—	—	—	3.2	5	
Output Load Transient Response	V _{IN} 3.3 V, V _{OUT} 0.8 V	I _O 2.5 to 5 A @ 1 A / μs settle to 2%	Figure 16 Figure 17	—	—	350	400	μs
	V _{IN} 5.0 V, V _{OUT} 3.3 V			—	—	140	200	
Load Transient Peak Deviation	V _{IN} 3.3 V, V _{OUT} 0.8 V	I _O 2.5 to 5 A @ 1 A/μs settle to 2%	Figure 16 Figure 17	—	—	210	244	mV pk
	V _{IN} 5.0 V, V _{OUT} 3.3 V			—	—	150	220	
Output Voltage Trim ¹ V ₁ , V ₂ , V ₃ , V ₄	—	See Table 9 on page 17						
Sequence Time Delay	See Table 8 on page 13							
MTBF	MFP0507S/H	AIF @ 55°C	—	—	—	1680	—	kHrs
	MFP0507S/K		—	—	—	6722	—	

Table 3 – Notes

- V_{OUT} is defined by the subscript after the V: V₁= 0.8 V, V₂ = 1.6 V, V₃ = 2.5 V, V₄ = 3.3 V
- Guaranteed stable up to maximum capacitance.
- Test condition at V_{OUT} at 3.3 V based on worst case setpoint condition.

Maximum Flexible Power (MFP) Single Output Point of Load

MFP0507S, 3 TO 6 VOLT INPUT, 7 AMP, DC-DC CONVERTER

PIN OUT			
Pin Number	Designation	Function	If Pin is not Used
1	ENABLE	Enable, provides remote turn on and off	Leave open
2	+V IN	Positive Input	Always used
3	V IN COM	Input Common	Always used
4	SYNC	Synchronization	Leave open
5	SENSE	Sense, voltage drop compensation	Connect to + V _{OUT} pin 10
6	SHARE	Current Share, parallel operation, or current monitor	Leave open
7	TRIM A	Preset Output Voltage and Trim	See Figure 5 on page 12 and Table 9 on page 17
8	TRIM B	Preset Output Voltage and Trim	See Figure 5 on page 12 and Table 9 on page 17
9	V OUT COM	Output Common (also SENSE Return)	Always used
10	+V OUT	Positive Output	Always used

TABLE 4: MFP0507S PIN OUT

Maximum Flexible Power (MFP) Single Output Point of Load

MFP0507S, 3 TO 6 VOLT INPUT, 7 AMP, DC-DC CONVERTER

MODEL NUMBERING KEY

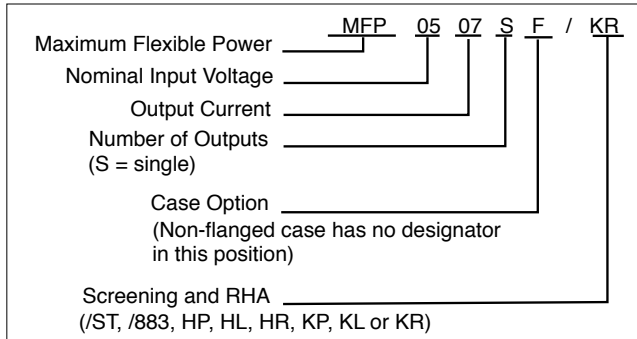

FIGURE 1: MODEL NUMBERING KEY

SMD NUMBER

STANDARD MICROCIRCUIT DRAWING (SMD)	MFP SIMILAR PART
5962R1120901KXC	MFP0507S/KR
The SMD number shown is for Class K screening and Radiation Hardness Assurance (RHA) level R. See the SMD for the numbers for other screening levels. For exact specifications for an SMD product, refer to the SMD drawing. SMDs can be downloaded from: https://landandmaritimeapps.dla.mil/programs/smcr	

TABLE 5: SMD NUMBER CROSS REFERENCE

MODEL NUMBER OPTIONS ¹ TO DETERMINE THE MODEL NUMBER ENTER ONE OPTION FROM EACH CATEGORY IN THE FORM BELOW.				
CATEGORY	Base Model, Input Voltage and Output Current	Case Option ²	Screening ³	RHA ⁴
	MFP0507S	(non-flanged, leave blank)	/ST	NA
		F (flanged)	/883	NA
			O	O
			H	P
			K	L
				R
FILL IN FOR MODEL # ⁵	<u> MFP0507S </u>	/	_____	_____
Notes 1. See Figure 1 above for an example of a model number. 2. Case Options: For the standard case (Figure 2 on page 8) leave the Case Option blank. For the flanged case option (Figure 3 on page 9), insert the letter F in the Case Option position. 3. High Reliability Screening: A screening level of /ST is standard screening and /883 is Class H screening. Space Screening: A screening level of O is a space prototype and is only available with RHA O. See Table 10 on page 20 and Table 11 on page 21 for more information. 4. RHA: Interpoint model numbers use an "O" in the RHA designator position to indicate the "-" (dash) radiation hardness assurance level of MIL-PRF-38534, which is defined as "no RHA." RHA O is only available with screening level O. See Table 11 on page 21 for more information. 5. If ordering by model number add suffix "-Q" to request solder dipped leads (MFP0507S/KR-Q). Available only for Class H or K.				

TABLE 6: MODEL NUMBER OPTIONS

Maximum Flexible Power (MFP) Single Output Point of Load

MFP0507S, 3 TO 6 VOLT INPUT, 7 AMP, DC-DC CONVERTER

MECHANICAL INFORMATION

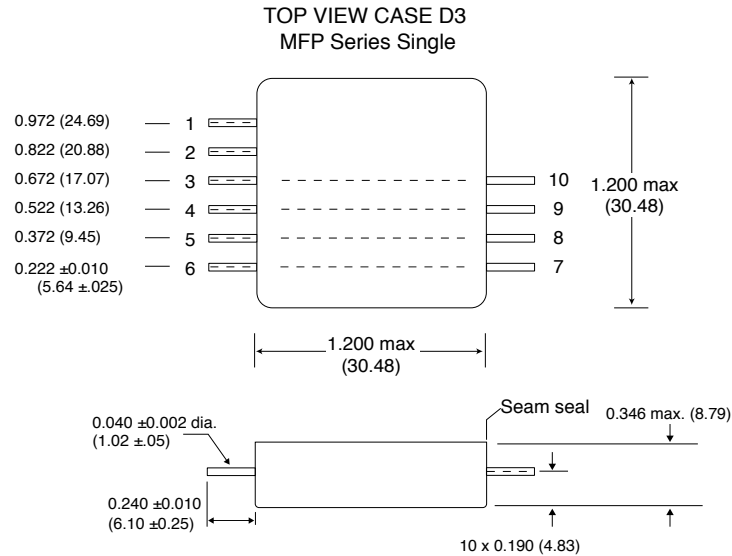

Weight: 26 grams maximum

Case dimensions in inches (mm)

Tolerances, unless otherwise specified,

X.XXX (X.XX) = ±0.005 (0.13)

X.XX (X.X) = ±0.01 (0.30)

Pin and hole placement ±0.0035 (±0.089)

CAUTION

Heat from reflow or wave soldering may damage the device. Solder pins individually with heat application not exceeding 300°C for 10 seconds per pin.

Materials

Header - Cold Rolled Steel/Nickel, /ST and /883 have gold plated headers

Cover - Kovar/Nickel

Pins - 3:1 Cu Cored alloy 52/Gold over Nickel, compression glass seal

Gold plating of 50 - 150 microinches included in pin diameter

Seal hole: 0.091 ±0.003 (2.31 ±0.08)

Please refer to the numerical dimensions for accuracy.

FIGURE 2: MFP0507S CASE DIMENSIONS

Maximum Flexible Power (MFP) Single Output Point of Load

MFP0507S, 3 TO 6 VOLT INPUT, 7 AMP, DC-DC CONVERTER

MECHANICAL INFORMATION

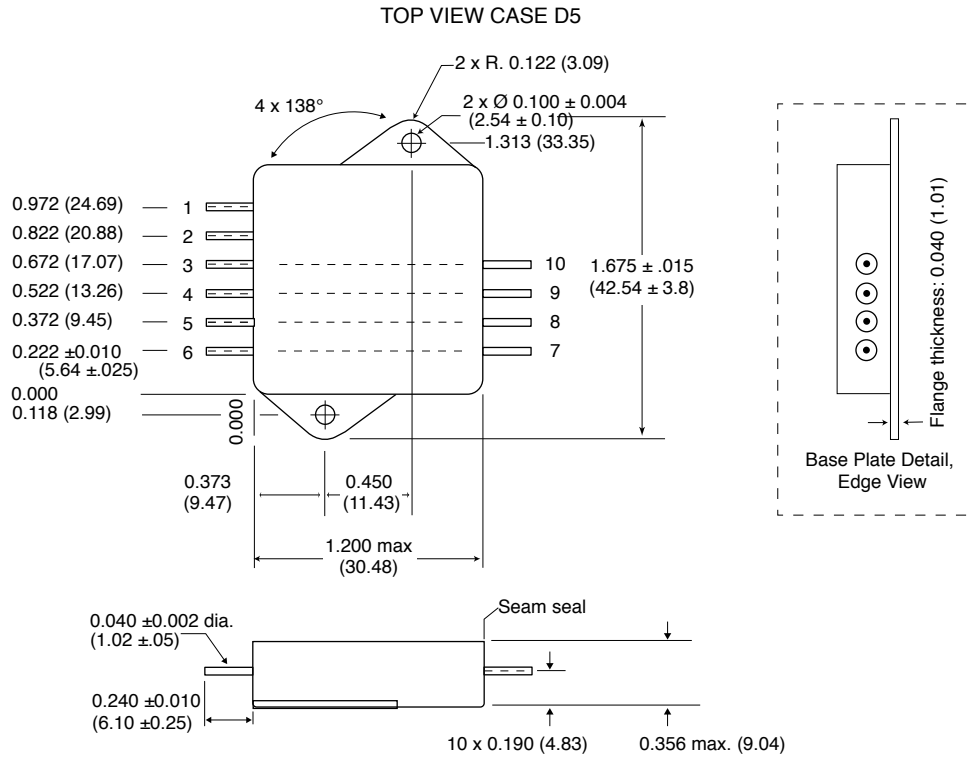

Weight: 32 grams maximum

Case dimensions in inches (mm)

Tolerances, unless otherwise specified,
 X.XXX (X.XX) = ±0.005 (0.13)
 X.XX (X.X) = ±0.01 (0.30)
 Pin and hole placement ±0.0035 (±0.089)

CAUTION

Heat from reflow or wave soldering may damage the device. Solder pins individually with heat application not exceeding 300°C for 10 seconds per pin.

Materials

- Header - Cold Rolled Steel/Nickel/Gold, /ST and /883 have gold plated headers
- Cover - Kovar/Nickel
- Pins - 3:1 Cu Cored alloy 52/Gold over Nickel, compression glass seal
- Gold plating of 50 - 150 microinches included in pin diameter
- Seal hole: 0.091 ± 0.003 (2.31 ± 0.08)

Please refer to the numerical dimensions for accuracy.

FIGURE 3: MFP0507SF CASE DIMENSIONS

Maximum Flexible Power (MFP) Single Output Point of Load

MFP0507S, 3 TO 6 VOLT INPUT, 7 AMP, DC-DC CONVERTER

THERMAL AND MOUNTING CONSIDERATIONS

THERMAL CONSIDERATIONS

The MFP is designed to be mounted close to the point-of-use which, in many cases, may be on a printed circuit board. The high efficiency of the MFP reduces the issues normally associated with the converter's internal dissipation. The maximum internal dissipation occurs when the product is configured as a 3.3 volt output at full load. This condition will result in a dissipation of not more than 1.78 watts. This dissipation is nearly uniformly distributed over the base area of 1.4 square inches. Full load power loss is largely independent of output voltage, for instance at 0.8 volts and full load the internal power loss maximum is again 1.78 watts.

In order to determine the cooling or heat sinking requirements in the application, the maximum product power dissipation should be calculated from the product efficiency and output power. Graphs and tabled values in the specification table can be used to find the efficiency given the input voltage, selected output voltage and output load. The internal dissipation, difference between output and input power, can be calculated from the equation below.

where:

P_{OUT} = output power

ϵ = efficiency

$$P_{DISS} = P_{OUT} (1 - \epsilon) / \epsilon$$

Φ = thermal resistance of converter attachment to board

$$\Delta T = P_{DISS} \times \Phi$$

$$T_{CASE} = T_{BASE} + \Delta T$$

Many applications will not require special efforts at cooling, however, this depends on ambient temperatures, adjacent components, and other factors.

If product cooling is required for safe operation convection and/or conduction can be used. Thermal considerations require that the base of the MFP be maintained at a safe temperature of less than the maximum rating. All components internal to the MFP are bonded to the metal base of the package. The base is the surface that is important if conduction cooling is used. It is a good practice to bond the device to the PCB or mounting surface with a thermally conductive pad. Such pads provide some degree of conduction cooling to the mounting surface depending on the amount of voiding at the interface. In the case of the side leaded MFP package, this thermal pad will firmly locate the device to the surface so that the lead connections only manage the electrical requirements and not the mechanical requirements.

In Figure 4 below, the thermal rise internal to the MFP can be seen to be only 6°C. This low thermal rise gives the end user more flexibility in board design options to meet applicable derating guidelines.

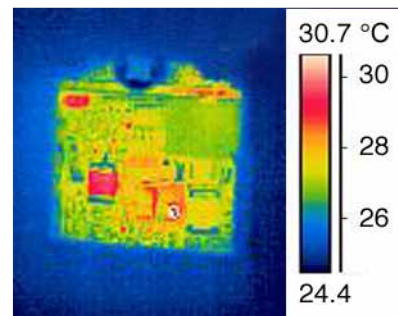

FIGURE 4: INFRARED IMAGE MFP AT FULL LOAD WITH 6 V_{IN}, 3.3 V_{OUT}

Maximum Flexible Power (MFP) Single Output Point of Load

MFP0507S, 3 TO 6 VOLT INPUT, 7 AMP, DC-DC CONVERTER

THERMAL AND MOUNTING CONSIDERATIONS (CONTINUED)

MOUNTING CONSIDERATIONS

The recommended mounting material is Chomeric's double-sided adhesive materials for attachment of the MFP to a circuit board or metal surface.

Because of the MFP's efficiency the thermal characteristics of the Chomeric materials are not required even though the Chomeric material provides good thermal conductivity.

The following information refers to products attached using Chomeric double-sided adhesive.

Vibration Testing

The MFP was tested in Random vibration using both the T1680 and T404 to mount the units to an aluminum vibration fixture. Testing was performed to the most severe level in MIL-STD-883 Method 2026; Condition 2, Letter K, overall G_{RMS} 51.1, for 15 minutes per axis, 3 axes and passed. No mounting detachment occurred.

Application

Recommended size for the adhesive tapes is 1.18 x 1.18 inches. Application of the tapes is a matter of peeling the release liners and attaching to the MFP and circuit board respectively. See Chomeric's data sheets and application notes for details. The T404 material does require higher application pressure. The T1680 material is specifically made for low pressure attachment of hybrids, ceramic and flat packages.

Removal

Refer to Chomeric's application notes for Thermattach Tape.

Specifications

Refer to Table 7: Chomeric Material Specifications for thermal conductivity, temperature range and out-gassing.

TABLE 7: CHOMERIC MATERIAL SPECIFICATIONS

MATERIAL	THERMAL CONDUCTIVITY	TEMPERATURE RANGE	OUTGASSING DATA		MOUNTING APPLICATION
	W/M-K	°C	% TVM	% CVCM	
CHO-THERM 1671 (Note 2)	2.6	-60 to +200	0.76	0.07	Rougher surfaces
CHO-THERM T1680 (Note 1)	0.65	-60 to +200	1.27	0.23	Smooth surfaces
THERMATTACH T404 (Note 1)	0.4	-30 to +125	0.53	0.02	Smooth surfaces

Table 7 – Notes

1. Chomeric's Thermattach Tape T404 and Cho-Therm T1680 are two excellent choices for circuit board mounting. Both have a Kapton insulating barrier with pressure sensitive adhesive (PSA) on both sides.

2. Chomerics Cho-Therm 1671 is a good choice for mounting on rougher surfaces. This material has a fiberglass barrier with PSA on one side. It can be obtained with PSA on both sides if needed.

Maximum Flexible Power (MFP) Single Output Point of Load

MFP0507S, 3 TO 6 VOLT INPUT, 7 AMP, DC-DC CONVERTER

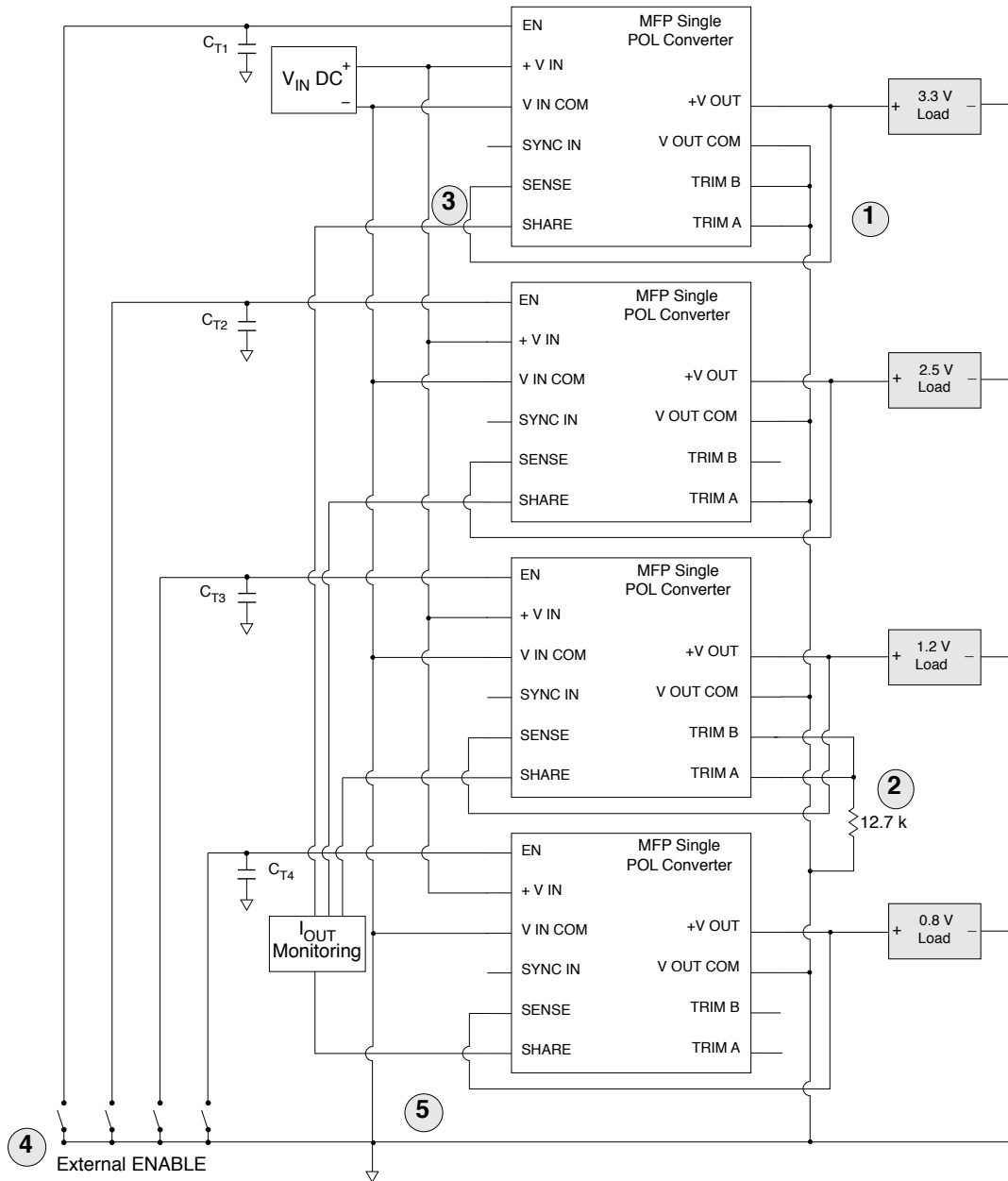

FIGURE 5: TYPICAL CONNECTION DIAGRAM
ENABLE, TRIM, SENSE, AND I_{OUT} MONITORING

For more information:

- ① ② TRIM section
- ③ Remote SENSE section
- ④ ENABLE section, sequencing. Table 8 on page 13 lists C_T values.
- ⑤ SHARE section

DESIGN RECOMMENDATIONS

The MFP is designed to be used with a low impedance power source. If the inductance to the MFP input is not negligible, it is recommended that the inductance is kept to less than 1 μ H per MFP converter. For additional information please contact power application support at powerapps@crane-eg.com.

Maximum Flexible Power (MFP) Single Output Point of Load

MFP0507S, 3 TO 6 VOLT INPUT, 7 AMP, DC-DC CONVERTER

ENABLE

The MFP provides an enable pin that will allow normal power conversion to occur if left open or unconnected. The ENABLE pin allows remote turn-on and turn-off control of the MFP. Connecting this pin to ground will disable power conversion, resulting in no output voltage and greatly reduced current consumption. The MFP ENABLE function will work with an open collector device connected to the pin or with a logic high voltage from a digital device as long as the logic high voltage is greater than the minimum voltage listed in the specification for enabled operation. The enable pin is active high at ≥ 2.3 volts or with a floating input.

Sequencing: The start-up of the MFP can be delayed with the addition of an external capacitor connected to the ENABLE pin as shown in Figure 6. This feature is useful in sequencing the start-up of multiple point of load converters in a system requiring a specific startup sequence for various low-voltage loads. The startup delay is roughly equal to 1 millisecond per microfarad of capacitance. More precise external capacitance values can be found in Table 8 where it can be seen that there is a variation in startup delay time as the input voltage varies. The listed delay is from the beginning of application of power to the beginning of internal power conversion. There will be an additional delay as the power converter begins a normal start-up sequence and ramps to final output voltage.

SYNC

The MFP includes a synchronization feature, a key capability in low noise system design. The internal conversion oscillator can be synchronized with a system clock or with a bus voltage source. The MFP is designed to synchronize with a 300 kHz system but can be synchronized with sources up to 600 kHz, a frequency range used by many DC-DC converters. A synchronized system prevents the generation of low frequency sub harmonics in the audio range. The synchronization input amplitude can range from 3 to 6 volts. Figure 18 on page 19 illustrates the relationship between operating frequency, temperature and input voltage.

The external synchronization timing cycle can be varied cycle to cycle for systems employing spread-spectrum clocking or for slave sharing clock interleaving. The dc level of the sync pin can be used to detect the state of the input voltage protection switch.

FIGURE 6: ENABLE AND SYNC EQUIVALENT CIRCUIT

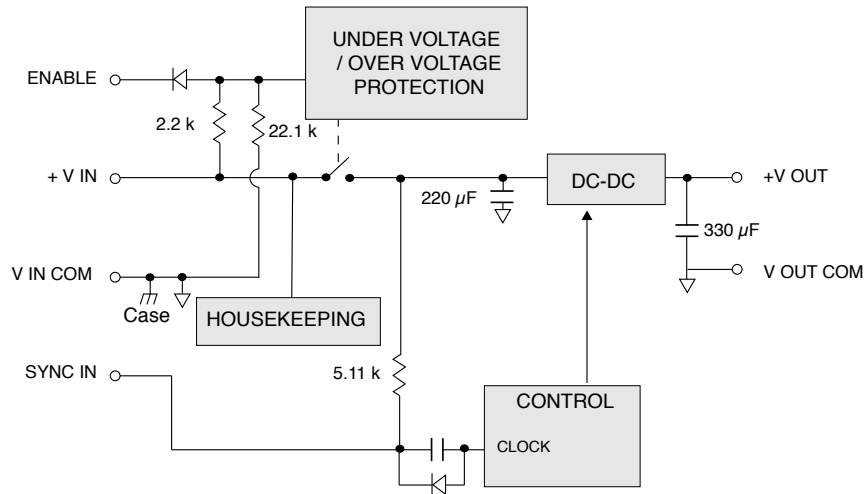

TABLE 8: ENABLE CAPACITANCE VALUES FOR START-UP DELAY

ENABLE CAPACITANCE: DELAY FROM ENABLE RELEASE TO START OF OUTPUT RISE (25°C)												UNITS
CAPACITANCE (C _T)	0.22	0.33	0.47	0.68	1.0	1.5	2.2	3.3	4.7	6.8	10	µF
V _{IN} 3.3 V	0.8	1.1	1.6	2.2	3.1	4.6	6.7	10.0	14.1	20.2	29.7	ms
V _{IN} 5.0 V	0.4	0.5	0.7	0.9	1.3	1.8	2.6	3.9	5.5	7.8	11.4	ms

Maximum Flexible Power (MFP) Single Output Point of Load

MFP0507S, 3 TO 6 VOLT INPUT, 7 AMP, DC-DC CONVERTER

+V_{IN} AND V_{IN} COMMON

Input Voltage

The input voltage range for normal operating conditions is 3.0 to 6.0 volts (Figure 7). For input ripple current see Figure 12 and Figure 13 on page 18.

The V_{IN} Common pin is connected to V_{OUT} Common and case ground. The input and output should share the same ground plane in the power system design.

ADDITIONAL INPUT BLOCK FEATURES

Input Under and Over Voltage Protection

The MFP includes a solid state switch on the input section. This switch opens for fault conditions including input voltages below the minimum and transient voltages above the maximum. The safe operating range includes ground and extends to 7.0 volts indefinitely and up to 15 volts as a time limited transient. The switch will only close when certain internal conditions are met, including the proper operation of the internal housekeeping supply and a safe input voltage range.

No Single Point Failure

The solid state switch (SSS) can be used to provide one additional level of reliability: "no single point failure" will result in a connection from input voltages to output loads. The SSS can be opened by grounding of the ENABLE Pin. The status of the SSS can be determined by detecting the voltage on the SYNC pin. A logic low on this pin indicates that the SSS is open.

No External Bias Required

An internal housekeeping supply that is active at inputs as low as 2 volts provides a boosted and regulated voltage supply for internal use. This internal supply is one of the reasons that this product can provide full power at very high efficiency at input voltages as low as 3 volts. No external power source or external bias is required.

Input Reflected Noise and Inrush Current Limit

Substantial input capacitance is included and the input solid state switch previously described is designed to provide associated inrush current limiting. The substantial input capacitance and high SSS provide a "pi" filter configuration that results in very low reflected ripple current. The very low input noise and inrush limiter make the MFP unique among point of load converters.

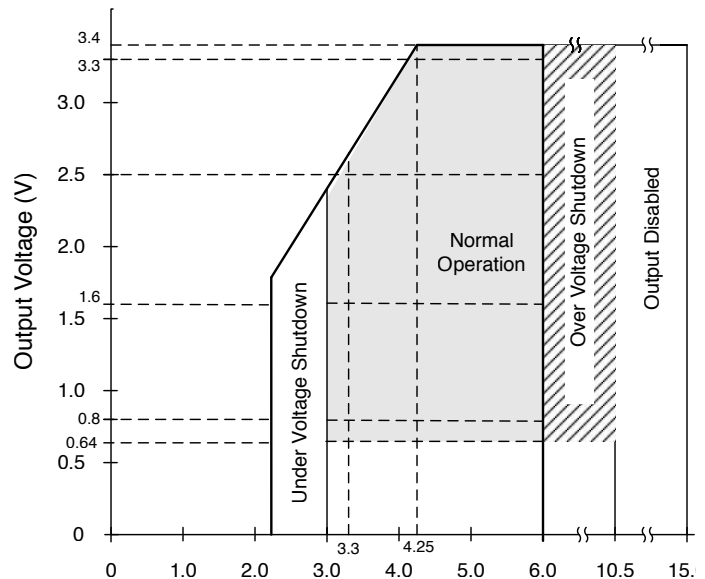

FIGURE 7: INPUT VOLTAGE VS MAXIMUM OUTPUT VOLTAGE

Maximum Flexible Power (MFP) Single Output Point of Load

MFP0507S, 3 TO 6 VOLT INPUT, 7 AMP, DC-DC CONVERTER

SENSE

The MFP includes a positive remote sense. The SENSE pin is intended to be used to maintain the desired preset voltage at the point-of-use by connecting the remote sense to the +Vout supply in close proximity to the load. Up to 0.27 volts of power line drop can be accommodated. If the SENSE pin lead is not connected to the output positive power pin, the output will rise a total of 0.27 volts.

The output voltage can be margined upward from the preset value as much as 0.2 volts by the addition of a resistor between the positive SENSE pin and the output power pin. The amount of increase in the output voltage by margining will reduce the available remote sense range by the same amount. The sum of margined voltage and voltage sense drop must be less than 0.2 volts.

Sense margining can be used to adjust V_{OUT} from 3.3 to 3.5. Connections must be made as close as possible to Common and to R_X . This method uses the SENSE pin's voltage compensation function to raise the output voltage. Therefore, there will not be an option to compensate for voltage drop at the load.

If connections have no voltage drop, the formula for the resistor is

$$R_X = \frac{1000}{\left[\frac{(0.2697)}{(V_{OUT} - 3.3)} - 1 \right]} \quad \text{in ohms}$$

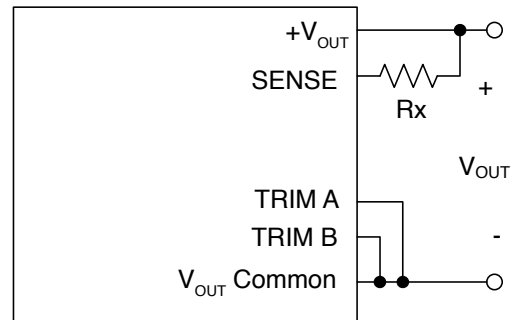

FIGURE 8: SENSE PIN VOLTAGE MARGINING
 V_{OUT} FROM 3.3 TO 3.5 1, 2, 3

Figure 8 – Notes

1. For external connections see Figure 5 on page 12.
2. See Table 9 on page 17 for output voltages from 0.64 to 3.3.
3. Not tested.

Maximum Flexible Power (MFP) Single Output Point of Load

MFP0507S, 3 TO 6 VOLT INPUT, 7 AMP, DC-DC CONVERTER

SHARE

The MFP includes a current share feature that allows multiple units to operate as a single supply capable of providing a total current that is the sum of the maximum from each of the units that are operated in parallel. In connecting units in parallel, the SHARE pin is connected between units and all but one unit, the master, will have TRIM A and TRIM B pins tied to the positive SENSE pin. The master will have the TRIM pins configured for the desired output voltage while the other units in parallel will match the current and voltage of the master unit.

Two connections are critical to sharing between two units. The SHARE pins of the two (or more) units must be tied together and the TRIM A and TRIM B outputs must be tied together and shorted to +Vout and SENSE for each unit that is not the Master. The master unit will be the one with the highest pre-set output voltage. In the case of Figure 9, callout 3, the master is configured with both TRIM pins open for a 0.8 V output.

The SHARE pin can be used as an output current monitor because the voltage on this pin is proportional to unit current. See Figure 5 on page 12, callout 5. Output currents corresponding to SHARE pin voltages are shown in Figure 18 on page 19. Connections for current monitoring are also shown in Figure 5 on page 12.

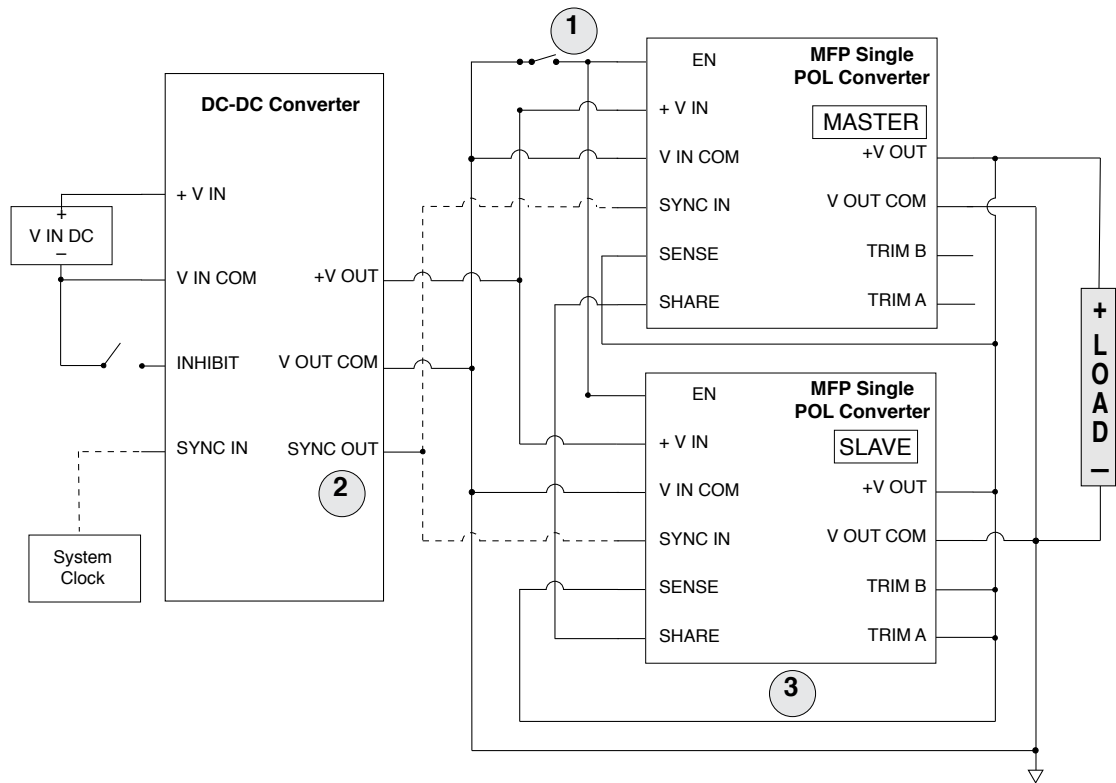

For more information:

- 1 ENABLE section
- 2 SYNC section
- 3 SHARE section (above)

FIGURE 9: TYPICAL SHARE CONNECTION WITH OPTIONAL SYNC

Maximum Flexible Power (MFP) Single Output Point of Load

MFP0507S, 3 TO 6 VOLT INPUT, 7 AMP, DC-DC CONVERTER

TRIM A AND TRIM B

Output Voltage Set and Adjustment

The MFP0507S, single output model has the flexibility to be set for any voltage from 0.64 to 3.3 volts. The MFP includes five precision set-points that can be accomplished with pin connections alone and no trim resistor. An open circuit on both TRIM pins results in a 0.80 volts output, grounding one or the other or both pins results in precise output voltages of 1.6, 2.5 or 3.3 volts. One other preset voltage is possible using the SENSE pin. Connecting both trim pins to the positive SENSE pin results in 0.64 volts. Output values of 0.8 to 3.5 volts can be set with the use of external trim resistors in series with the trim pins to ground.

Any voltage intermediate to the pre-set voltages is available by adding a trim resistor between Common and both TRIM pins. Table 9 lists available pin-configurable and adjust/trim output voltages. See Figure 10 for output current under specific operating conditions.

OUTPUT VOLTAGE USING PIN CONFIGURATIONS OR TRIM RESISTORS			
Desired Voltage		Pin Configurable	TRIM Resistor (R_T) ¹ from ground to TRIM A and TRIM B
0.64 ²	Fixed SENSE pin V_s	Both TRIM A and TRIM B connected to SENSE	—
0.8	Fixed V_1	Both TRIM A and TRIM B open	—
0.9	Adjust	—	57.6 k
1.0	Adjust	—	27.4 k
1.2	Adjust	—	12.7 k
1.5	Adjust	—	6.19 k
1.6	Fixed V_2	TRIM A open TRIM B grounded	—
1.8	Adjust	—	3.57 k
2.0	Adjust	—	2.61 k
2.5	Fixed V_3	TRIM A grounded. TRIM B open	—
3.3	Fixed V_4	Both TRIM A and TRIM B grounded	—

TABLE 9: USER CONFIGURABLE OUTPUT VOLTAGES^{1, 3}

+ V_{OUT} AND V_{OUT} COMMON

Due to the Buck topology, the required output voltage of the MFP must always be at least 0.8 V lower than the input. Precise values of achievable output voltages and currents as a function of V_{IN} are shown in Figure 9 on page 16.

See page Figure 12 and Figure 13 on page 18 for typical output ripple plots.

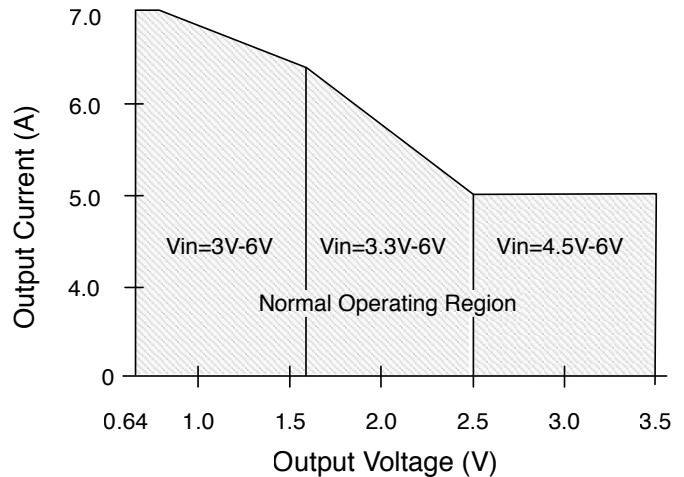

FIGURE 10: MAXIMUM RATED OUTPUT CURRENT

Table 9 – Notes

1. Formula for R_T in Table 7 for V_{OUT} below 3.3 and above 0.8 V:

$$R_T = \frac{6.031}{V_{OUT} - 0.804} - 2.4 \text{ in kOhms}$$

2. The output voltage of 0.64 is available for use but performance is not electrically specified.

3. See page Figure 8 on page 15.

Maximum Flexible Power (MFP) Single Output Point of Load

MFP0507S, 3 TO 6 VOLT INPUT, 7 AMP, DC-DC CONVERTER

TYPICAL PERFORMANCE PLOTS: 25°C CASE, 5 V_{IN}, 100% LOAD, FREE RUN, UNLESS OTHERWISE SPECIFIED.
 These are examples for reference only and are not guaranteed specifications.

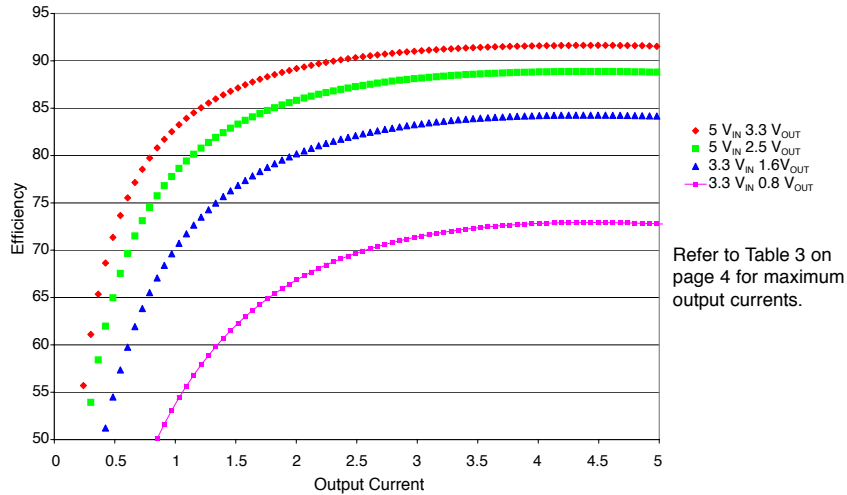
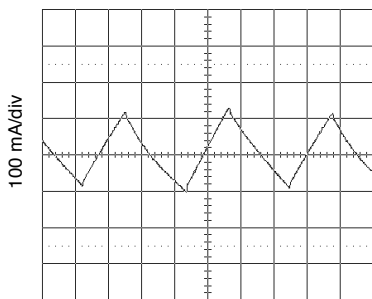
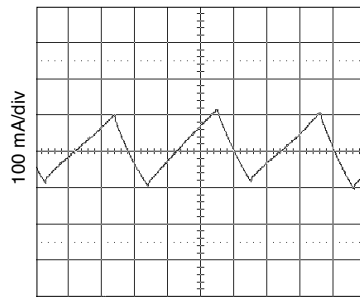

FIGURE 11: TYPICAL EFFICIENCIES



100 mA/div
 1 μs/div
 3.3 V_{IN}, 1.2 V_{OUT}, 5 A load
 MFP0507S Input Ripple (I_{IN})
 FIGURE 12



100 mA/div
 1 μs/div
 5 V_{IN}, 3.3 V_{OUT}, 5 A load
 MFP0507S Input Ripple (I_{IN})
 FIGURE 13

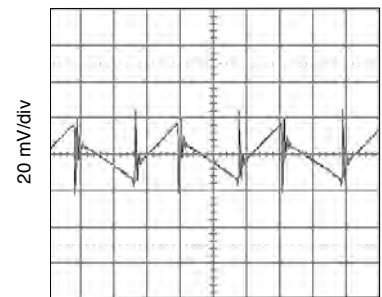

20 mV/div
 1 μs/div
 3.3 V_{IN}, 1.2 V_{OUT}, 5 A load
 MFP0507S Output Ripple
 FIGURE 14

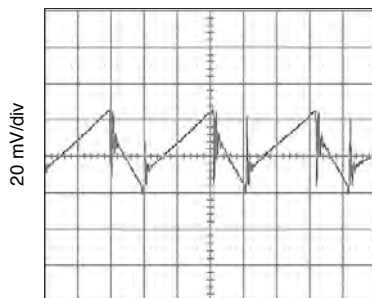

20 mV/div
 1 μs/div
 5 V_{IN}, 3.3 V_{OUT}, 5 A load
 MFP0507S Output Ripple
 FIGURE 15

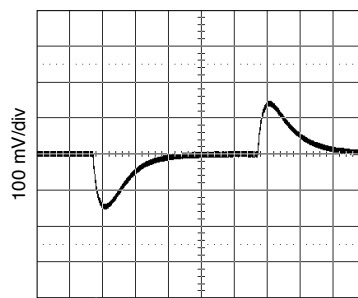

100 mV/div
 200 μs/div
 3.3 V_{IN}, 1.2 V_{OUT}, 5 A load
 MFP0507S Load Transient
 FIGURE 16

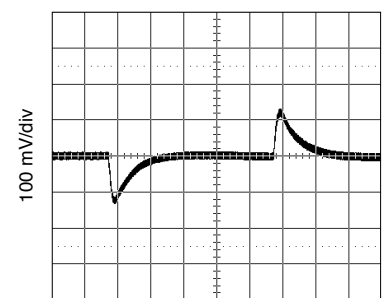

100 mV/div
 200 μs/div
 5 V_{IN}, 3.3 V_{OUT}, 5 A load
 MFP0507S Load Transient
 FIGURE 17

Maximum Flexible Power (MFP) Single Output Point of Load

MFP0507S, 3 TO 6 VOLT INPUT, 7 AMP, DC-DC CONVERTER

TYPICAL PERFORMANCE PLOTS: 25°C CASE, 5 VIN, 100% LOAD, FREE RUN, UNLESS OTHERWISE SPECIFIED. These are examples for reference only and are not guaranteed specifications.

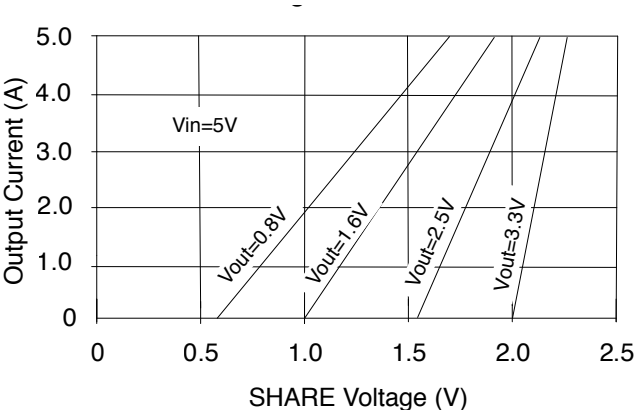

FIGURE 18 : SHARE AS MONITOR FOR OUTPUT CURRENT

Note on SHARE: Because there is a predictable relationship between SHARE pin voltage and load current, the SHARE pin can be monitored to indicate load current when the share function is not being used. Due to initial tolerance related variations in the exact SHARE voltage vs. load current relationship, it is recommended that the user perform a calibration by measuring the SHARE pin voltage at two or more load currents and calculating the V-SHARE vs. load slope and intercept. The graph in Figure 18 is indicative of what should be expected when generating such a relationship.

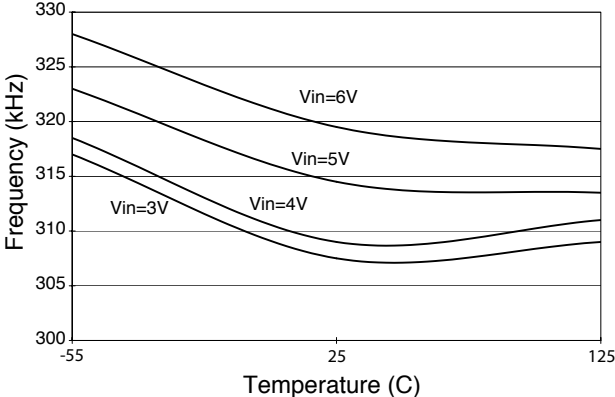

FIGURE 19 : TYPICAL OPERATING FREQUENCY VS TEMPERATURE AND VIN

This graph illustrates the performance of proprietary technology

Maximum Flexible Power (MFP) Single Output Point of Load

MFP0507S, 3 TO 6 VOLT INPUT, 7 AMP, DC-DC CONVERTER

MIL-PRF-38534 ELEMENT EVALUATION

COMPONENT-LEVEL TEST PERFORMED	NON-QML ¹	QML			
	PROTOTYPE	CLASS H		CLASS K	
	/O	/H		/K	
	M/S ²	M/S ²	P ³	M/S ²	P ³
Element Electrical	■	■	■	■	■
Visual		■	■	■	■
Internal Visual		■		■	
Temperature Cycling				■	■
Constant Acceleration				■	■
Interim Electrical				■	
Burn-in				■	
Post Burn-in Electrical				■	
Steady State Life				■	
Voltage Conditioning Aging					■
Visual Inspection					■
Final Electrical		■	■	■	■
Wire Bond Evaluation		■	■	■	■
SEM				■	
C-SAM: Input capacitors only ⁴			■		■

Notes

1. Non-QML products may not meet all of the requirements of MIL-PRF-38534.
2. M/S = Active components (Microcircuit and Semiconductor Die)
3. P = Passive components, Class H and K element evaluation. Not applicable to /ST element evaluation.
4. Additional test not required by H or K.

Definitions:

Element Evaluation: Component testing/screening per MIL-STD-883 as determined by MIL-PRF-38534
SEM: Scanning Electron Microscopy
C-SAM: C – Mode Scanning Acoustic Microscopy

TABLE 10: ELEMENT EVALUATION

Maximum Flexible Power (MFP) Single Output Point of Load

MFP0507S, 3 TO 6 VOLT INPUT, 7 AMP, DC-DC CONVERTER

ENVIRONMENTAL SCREENING DC-DC CONVERTERS /ST, /883 (CLASS H), /OO (PROTOTYPE), CLASS H AND K, RHA¹ P, L AND R

TEST PERFORMED	NON-QML ²		QML ³						
	STANDARD	PROTOTYPE	CLASS H				CLASS K		
	/ST	/OO ⁴	/883	/HP	/HL	/HR	/KP	/KL	/KR
Non-destruct wire bond pull, Method 2023			■ ⁵	■ ⁵	■ ⁵	■ ⁵	■	■	■
Pre-cap Inspection, Method 2017, 2032	■	■	■	■	■	■	■	■	■
Temperature Cycle (10 times) Method 1010, Cond. C, -65°C to +150°C, ambient		■	■	■	■	■	■	■	■
Constant Acceleration Method 2001, 3000 g		■	■	■	■	■	■	■	■
PIND, Test Method 2020, Cond. A			■ ⁵	■ ⁵	■ ⁵	■ ⁵	■	■	■
Pre burn-in test, Group A, Subgroups 1 and 4		■	■ ⁵	■ ⁵	■ ⁵	■ ⁵	■	■	■
Burn-in Method 1015, +125°C case, typical⁶									
96 hours		■							
160 hours			■	■	■	■			
2 x 160 hours (includes mid-BI test)							■	■	■
Final Electrical Test, MIL-PRF-38534, Group A,									
Subgroups 1 and 4: +25°C case	■	■							
Subgroups 1 through 6, -55°C, +25°C, +125°C case			■	■	■	■	■	■	■
Hermeticity Test, Method 1014									
Gross Leak, Cond. B ₂ , Kr85							■	■	■
Gross Leak, Cond. C ₁ , fluorocarbon	■	■	■	■	■	■			
Fine Leak, Cond. B ₁ , Kr85							■	■	■
Fine Leak, Cond. A ₂ , helium		■	■	■	■	■			
Radiography, Method 2012							■	■	■
Post Radiography Electrical Test, +25°C case							■ ⁵	■ ⁵	■ ⁵
Final visual inspection, Method 2009	■	■	■	■	■	■	■	■	■
RHA P: 30 krad(Si) total dose^{1, 7, 8}				■			■		
RHA L: 50 krad(Si) total dose^{1, 7, 8}					■			■	
RHA R: 100 krad(Si) total dose^{1, 7, 8}						■			■
SEE, LET 86 MeV cm²/mg^{1, 9}				■	■	■	■	■	■

Test methods are referenced to MIL-STD-883 as determined by MIL-PRF-38534.

Notes

1. Our Redmond facility has a DLA approved RHA plan for Interpoint power products. Our SMD products with RHA "P", "L" or "R" code meet DLA requirements.
2. Non-QML products may not meet all of the requirements of MIL-PRF-38534.
3. All processes are QML qualified and performed by certified operators.
4. "O" in the RHA designator position in Interpoint model numbers indicates DLA RHA "-" defined as no RHA.

5. Not required by DLA but performed to assure product quality.
6. Burn-in temperature designed to bring the case temperature to +125°C minimum. Burn-in is a powered test.
7. High dose rate test.
8. Low dose rate test. Tested up to 30 krad(si).
9. No destructive events or SEL.

TABLE 11: ENVIRONMENTAL SCREENING AND RHA LEVELS

